

CONNECTION: ACCEPTS PRE-SWAGED 3/4 TUBE WITH NUT AND FERRULE
 NOMINAL CRACKING PRESSURE: 10 - 20 PSI

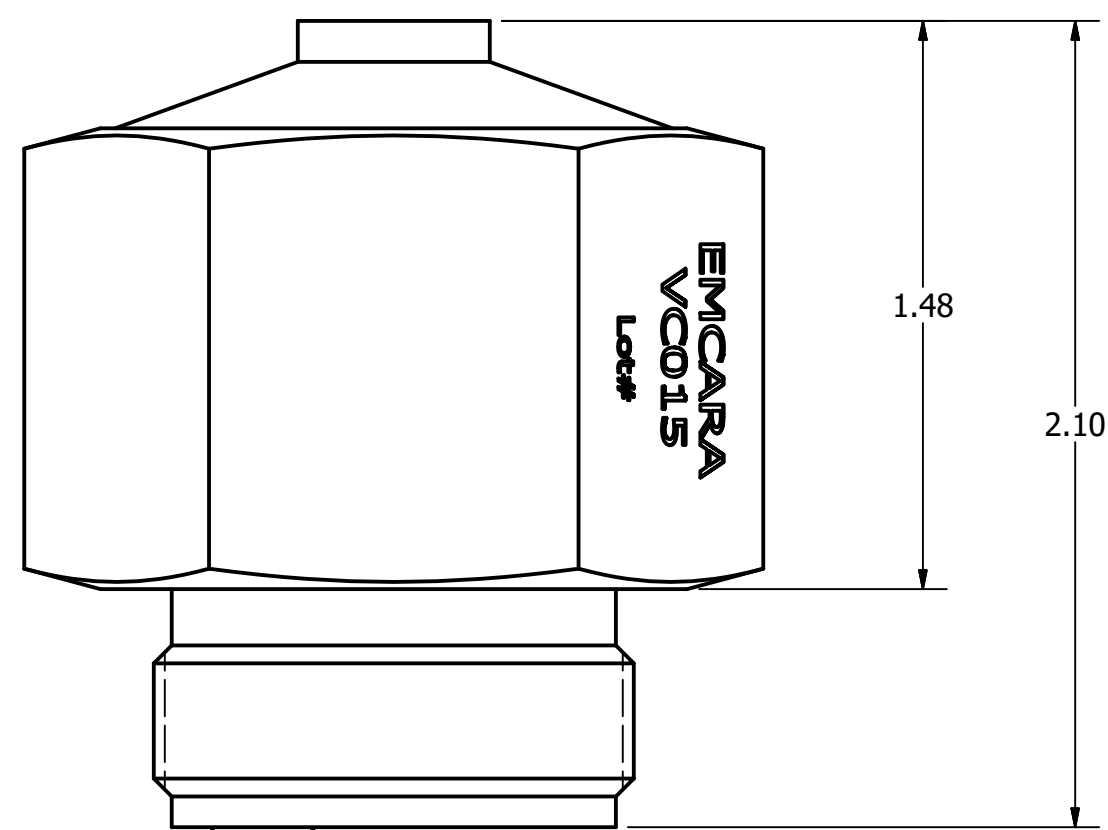

ACCEPTS PRE-SWAGED 3/4" TUBE

1-20 UNEF - 2A
 MOUNTS TO TUBE USING
 STANDARD NUT AND FERRULES

NOTES:

1. ALL EXTERNAL MATERIALS ARE STAINLESS STEEL
2. VITON O-RING ON POPPET
3. **NUTS AND FERRULES MUST BE PRESWAGED TO TUBE**

OPTIONS

VC015
 -NO NUTS OR FERRULES

VC015-GC
 -GENERIC NUTS AND FERRULES

VC015-SC
 -SWAGELOK NUTS AND FERRULES

THIS DRAWING CONTAINS PROPRIETARY INFORMATION AND MAY NOT BE DISCLOSED WITHOUT PRIOR WRITTEN CONSENT.

UNLESS OTHERWISE STATED:

ALL DIMENSIONS ARE IN
 IMPERIAL INCHES
 TOLERANCE:
 ONE PLACE DEC. = ±.05
 TWO PLACE DEC. = ±.01
 THREE PLACE DEC. = ±.005
 ANGLE = ± 1°

MATERIAL:

FINISH:

DO NOT SCALE DRAWING



TITLE:
 VENT CAP, 3/4"

SIZE	DWG. NO.	REV
C	VC015	NC
SCALE: 2 : 1	WEIGHT: N/A	SHEET 1 OF 1